

# FICHE D'HOMOLOGATION / HOMOLOGATION FORM



040-EJ-05



## COMMISSION INTERNATIONALE DE KARTING - FIA



### MOTEUR / ENGINE OK-Junior

|   |  |
|---|--|
| Constructeur / <i>Manufacturer</i>  | IAME S.p.A. S.U.   |
| Marque / <i>Make</i>  | <b>IAME</b>  |
| Modèle / <i>Model</i>   | <b>R 125 KJ</b>  |
| Catégorie / <i>Categorie</i>  | Groupe 2 / <i>Group 2</i>  |
| Durée de l'homologation / <i>Validity of the Homologation</i>   | 3 ans / <i>3 years</i>   |
| Nombre de pages / <i>Number of pages</i>  | 13   |
| La présente Fiche d'Homologation reproduit descriptions, illustrations et dimensions du moteur au moment de l'homologation CIK-FIA. | <i>This Homologation Form reproduces descriptions, illustrations and dimensions of the engine at the moment of the CIK-FIA homologation.</i> |
|    |    |
| Photo du moteur côté pignon /<br><i>Photo of engine drive side</i>  | Photo du moteur côté opposé /<br><i>Photo of engine opposite side</i>  |
| Signature et tampon de l'ASN /<br><i>Signature and stamp of the ASN</i>   | Signature et tampon de la CIK-FIA /<br><i>Signature and stamp of the CIK-FIA</i>   |
|    | <p><i>Jacob Nertoft</i><br/>Head of FIA Karting Department</p>   |

## INFORMATIONS TECHNIQUES / TECHNICAL INFORMATION

**A**

### Caractéristiques / Characteristics

| Le nombre de décimales doit être de 2 ou en accord avec la tolérance appliquée. /<br>The number of decimal places must be 2 or comply with the relevant tolerance. | Tolérances et remarques /<br>Tolerances & remarks |                       |
|--|---|-----------------------|
| <b>Cylindre / Cylinder</b>   |   |                       |
| Volume du cylindre / <i>Cylinder volume</i>  | 124.08 cm <sup>3</sup>                            | < 125 cm <sup>3</sup> |
| Alésage d'origine / <i>Original bore</i>   | 53.89 mm  |                       |
| Course / <i>Stroke</i>   | 54.40 mm  |                       |
| <b>Vilebrequin / Crankshaft</b>  |   |                       |
| Poids du vilebrequin complet, sans piston /<br><i>Weight of crankshaft complete, without piston</i>  | 1870.0 gr.  | minimum               |
| Dimensions des paliers / <i>Dimensions of bearings</i>   | 25.0 mm   |                       |
| Nombre des paliers / <i>Number of bearings</i>   | 2   |                       |
| <b>Bielle / Conrod</b>   |   |                       |
| Longueur (entre-axe) de la bielle / <i>Length between the axes of the conrod</i>   | 104.00 mm   |                       |
| Diamètre de la tête de bielle / <i>Diameter of big end</i>   | 26.00 mm  |                       |
| Diamètre du pied de bielle / <i>Diameter of small end</i>  | 19.00 mm  |                       |
| Poids de la bielle / <i>Weight of conrod</i>   | 87.0 gr.  | minimum               |
| <b>Piston / Piston</b>   |   |                       |
| Nombre de segments du piston / <i>Number of piston rings</i>   | 1   |                       |
| Poids du piston, segments du piston inclus /<br><i>Weight of the piston including piston rings</i>   | 104.0 gr.   | minimum               |
| Poids de l'axe de piston / <i>Weight of gudgeon pin</i>  | 25.0 gr.  | minimum               |
| <b>Arbre d'équilibrage / Balance shaft</b>   |   |                       |
| Poids de l'arbre d'équilibrage / <i>Weight of balance shaft</i>  | 193.0 gr.   | minimum               |
| Pourcentage d'équilibrage / <i>Percentage of balancing</i>   | 25 %  | minimum               |

**B**

### Angles d'ouverture / Opening angles

|   |   |
|---|---|
| Lumière d'échappement / <i>Exhaust port</i> | Selon le règlement / <i>Acc. to regulations</i> |
|---|---|

**C**

### Matériau / Material

|                                 |                               |
|---------------------------------|-------------------------------|
| Culasse / <i>Cylinder head</i>  | Al-Si or Al-Si+Fe or Al-Si+Cu |
| Cylindre / <i>Cylinder</i>      | Al-Si / FONTE                 |
| Carter / <i>Sump</i>            | Al-Si                         |
| Vilebrequin / <i>Crankshaft</i> | Steel / Coating               |
| Bielle / <i>Connecting rod</i>  | Steel / Coating               |
| Piston / <i>Piston</i>          | Al-Si                         |

E

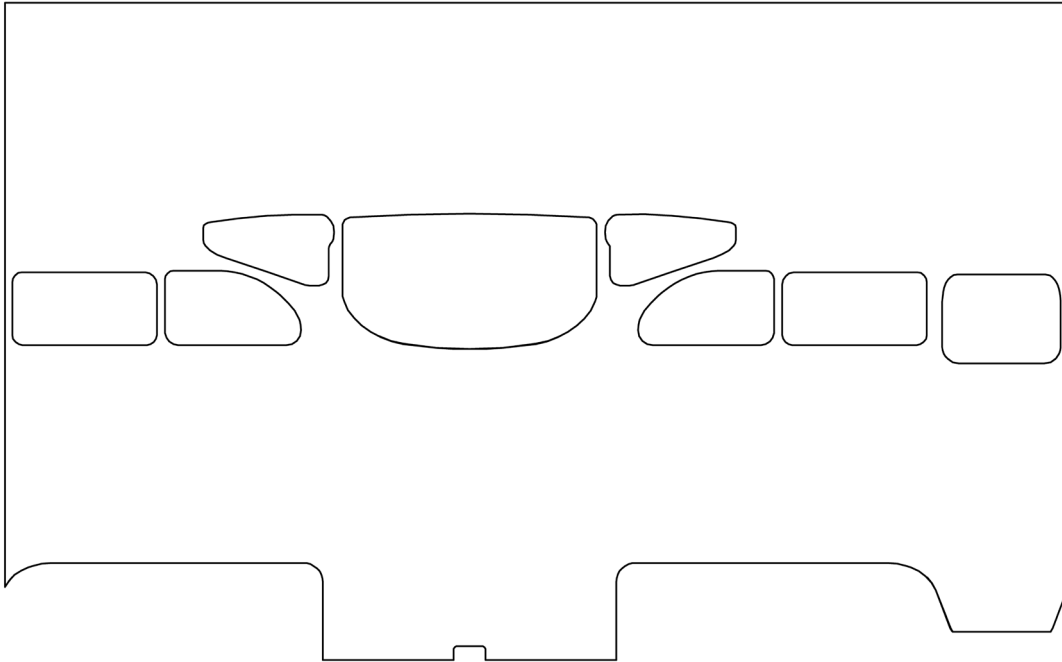
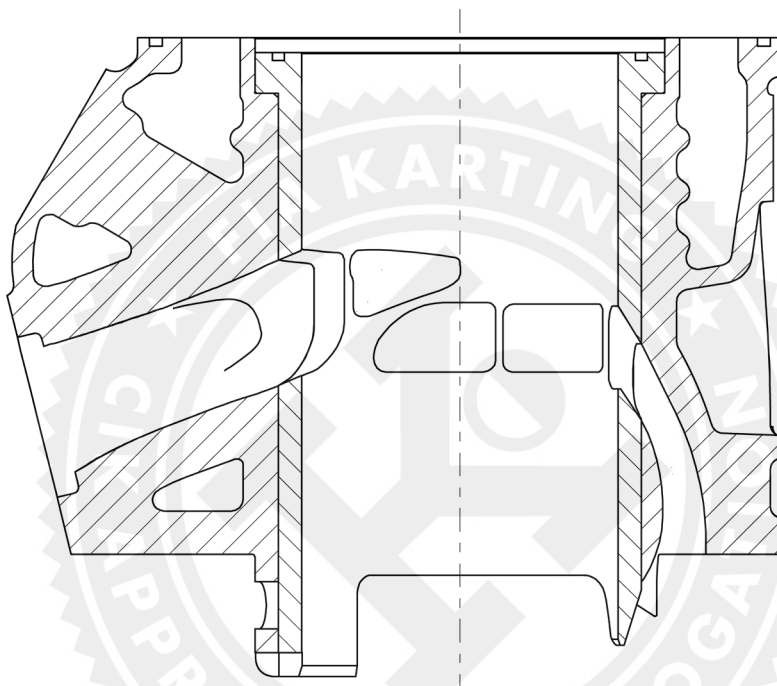
**Photos, dessins et graphiques / Photos, drawings and graphs****1. Cylindre et carter / Cylinder and crankcase**Dessin du développement du cylindre (sans dimensions) / *Drawing of the cylinder development (without dimensions)*Vue en coupe verticale du cylindre avec la chemise complet (sans dimensions) / *Vertical cross section view of the complete cylinder with liner (without dimensions)*

Dessin du pied du cylindre /  
Drawing of the cylinder base

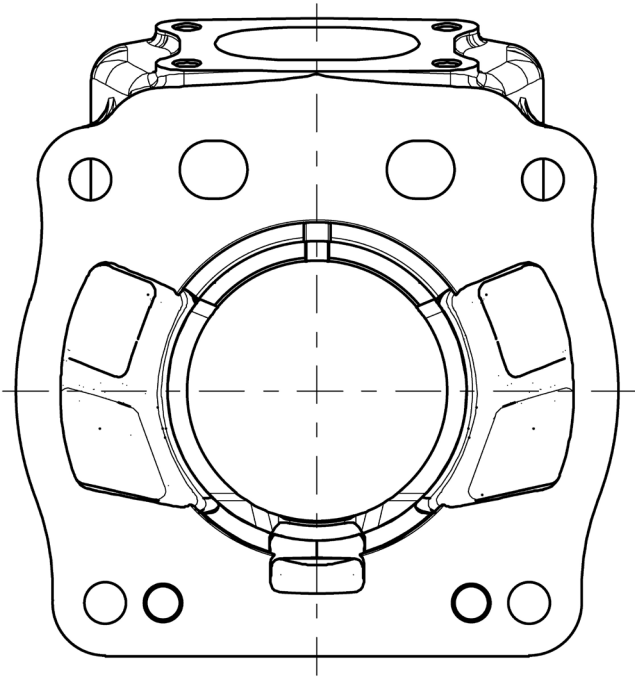

Photo du pied du cylindre /  
Photo of the cylinder base



Photo de l'intérieur du carter droit /  
Photo of the inside of the right crankcase

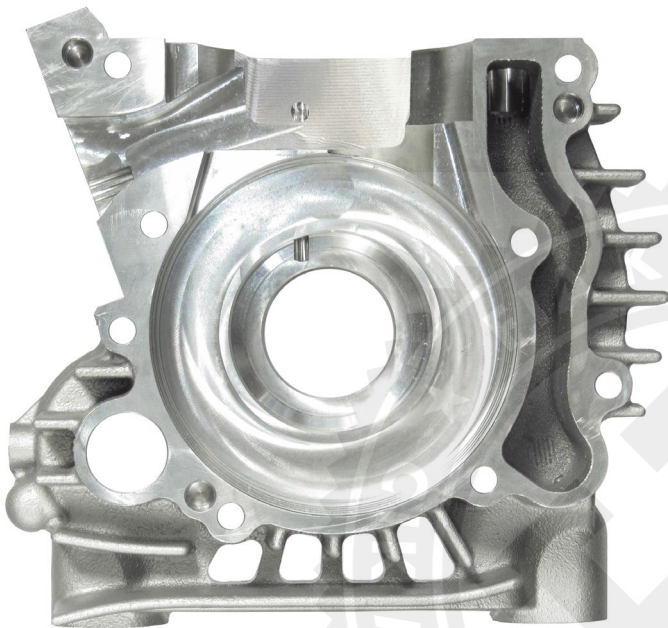
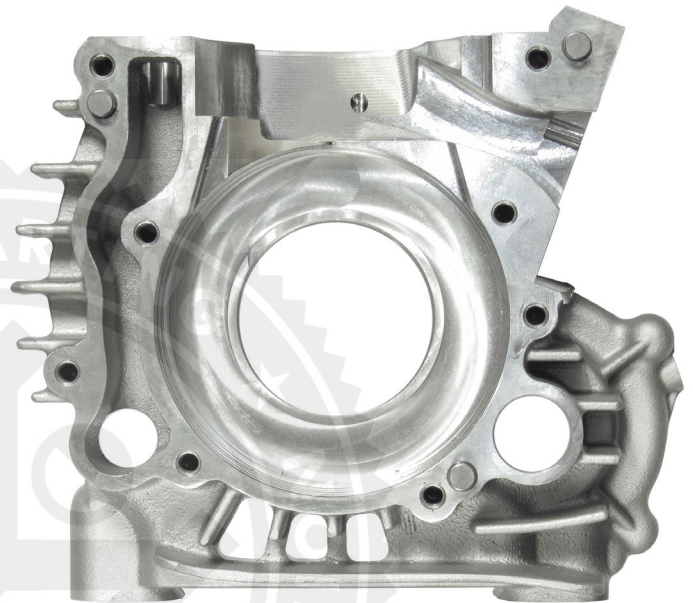

Photo de l'intérieur du carter gauche /  
Photo of the inside of the left crankcase



Dessin de la culasse et de la chambre de combustion (sans dimensions) /  
Drawing of the cylinder head and the combustion chamber (without dimensions)

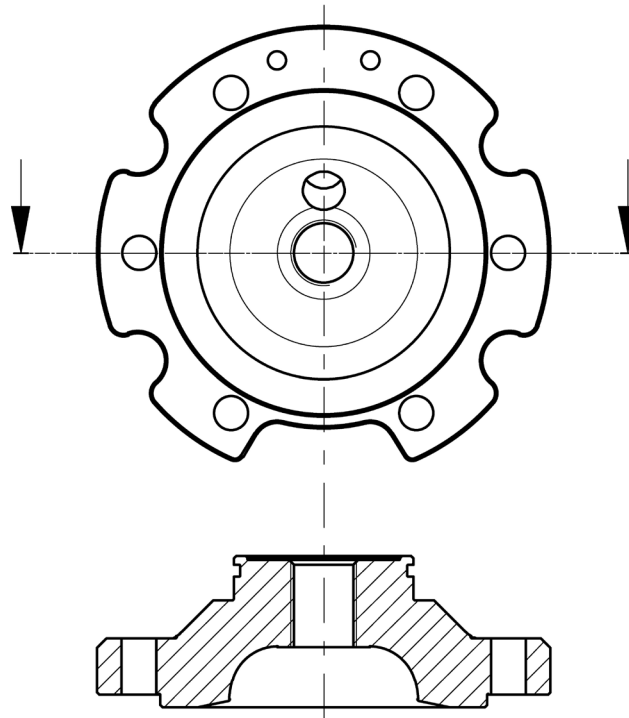
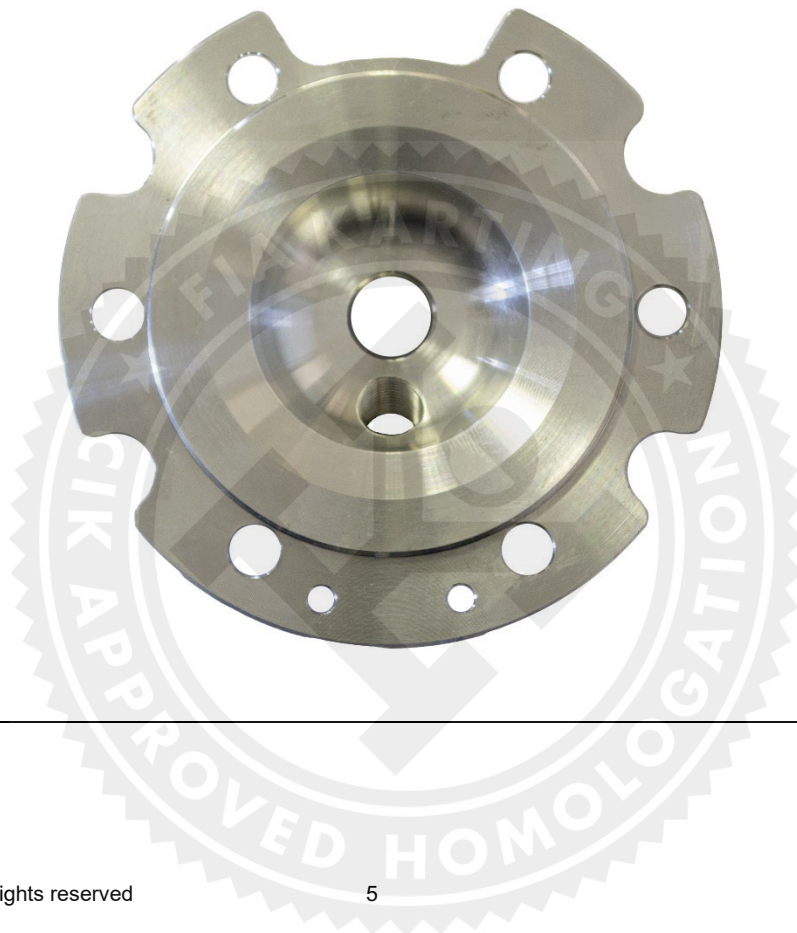

Photo de la culasse et de la chambre de combustion /  
Photo of the cylinder head and the combustion chamber



## 2. Vilebrequin, bielle et piston / Crankshaft, conrod and piston

Dessin du vilebrequin complet (dimensions sans tolérances) /  
Drawing of the complete crankshaft (dimensions without tolerances)

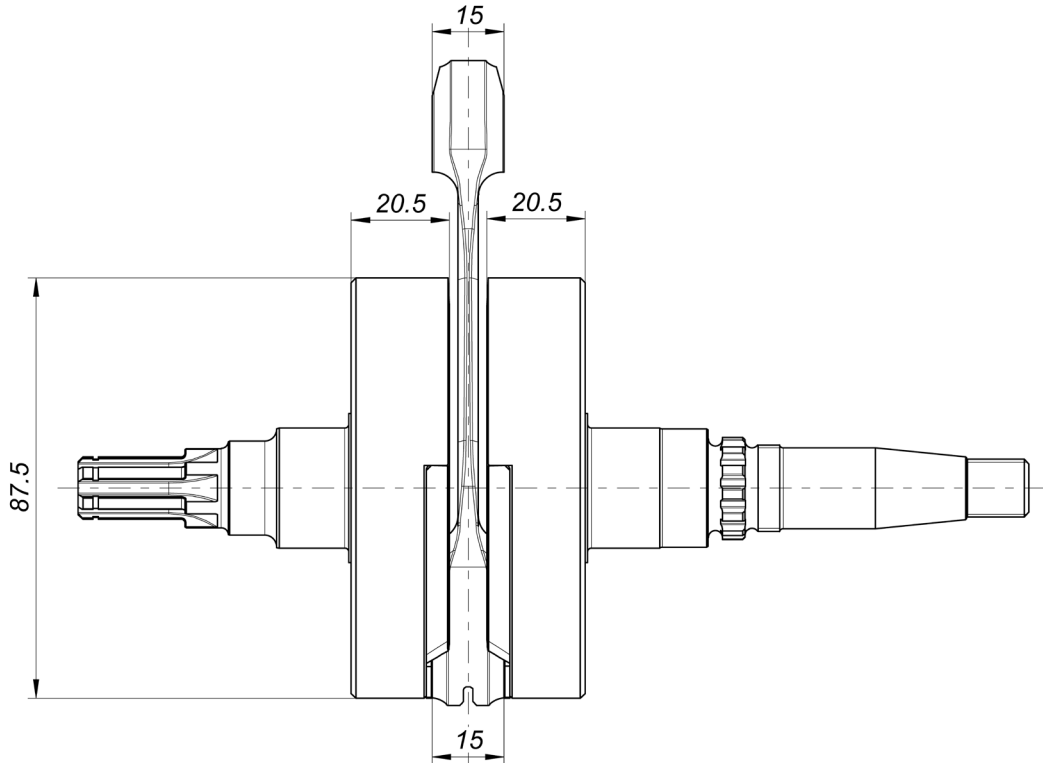
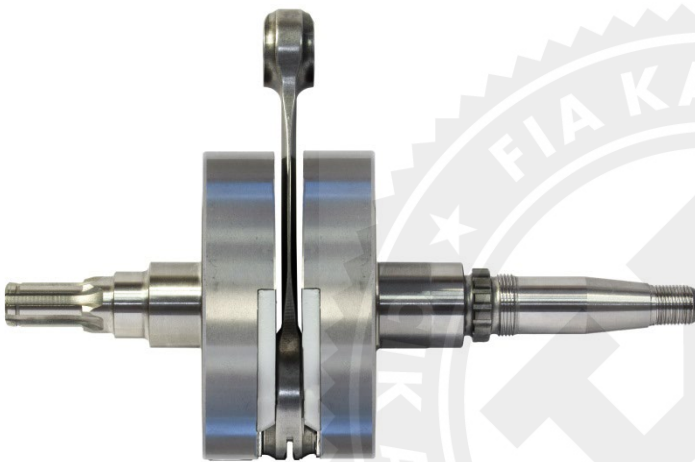

Photo du vilebrequin et de la bielle /  
Photo of the crankshaft and conrod

Photo de la bielle / Photo of the conrod



Dessin du piston (dimensions principales sans tolérances) /  
Drawing of the piston (main dimensions without tolerances)

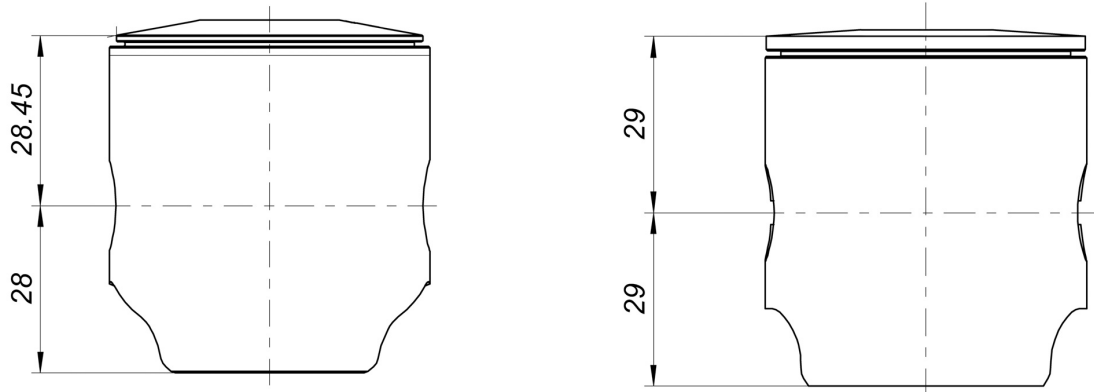

Photo du piston / Photo of the piston



**3. Arbre d'équilibrage / Balance shaft**

Dessin de l'arbre d'équilibrage (dimensions sans tolérances) /  
Drawing of the balance shaft (dimensions without tolerances)

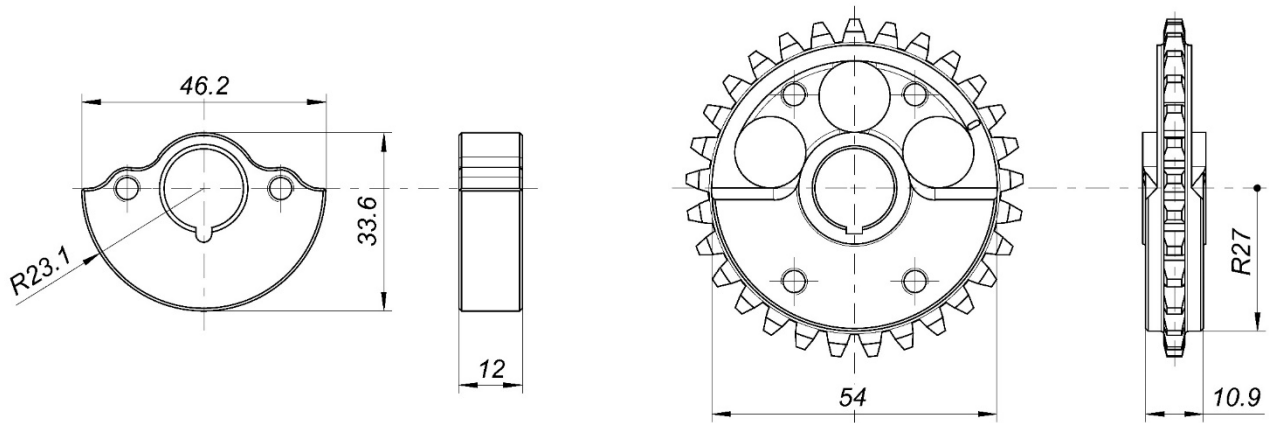

Photo de l'arbre d'équilibrage / Photo of the balance shaft



**4. Boîte à clapets / Reed valve**

Dessin de la boîte à clapets (dimensions sans tolérances) /  
Drawing of the reed box (dimensions without tolerances)

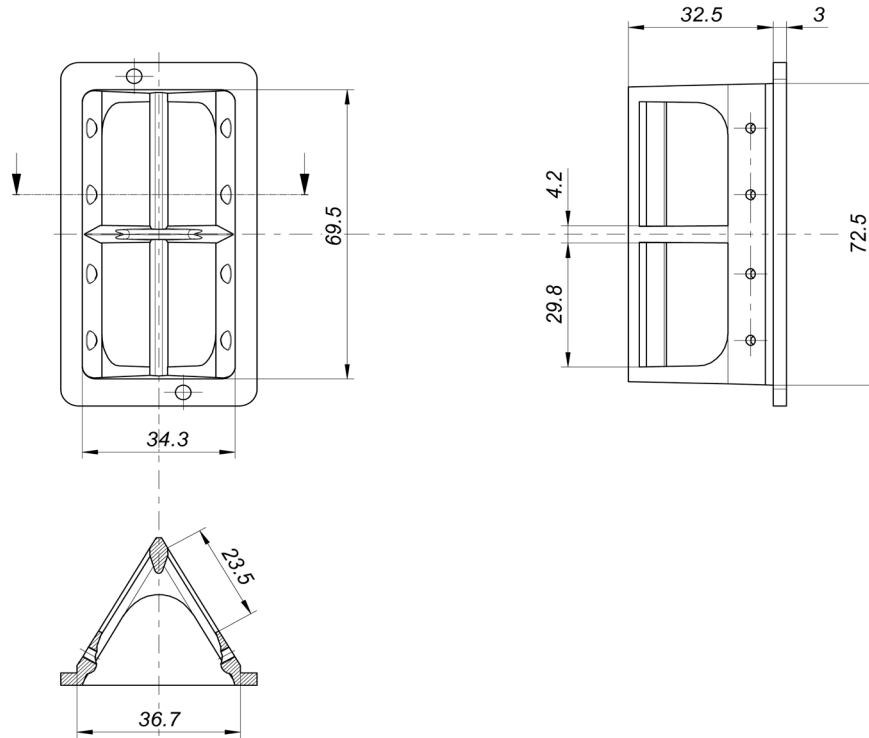

Photo de la boîte à clapets (sans clapets) / Photo of the reed box (without reeds)



**5. Moteur / Engine**

Photo du moteur complet de l'avant /  
Photo of the complete engine front side

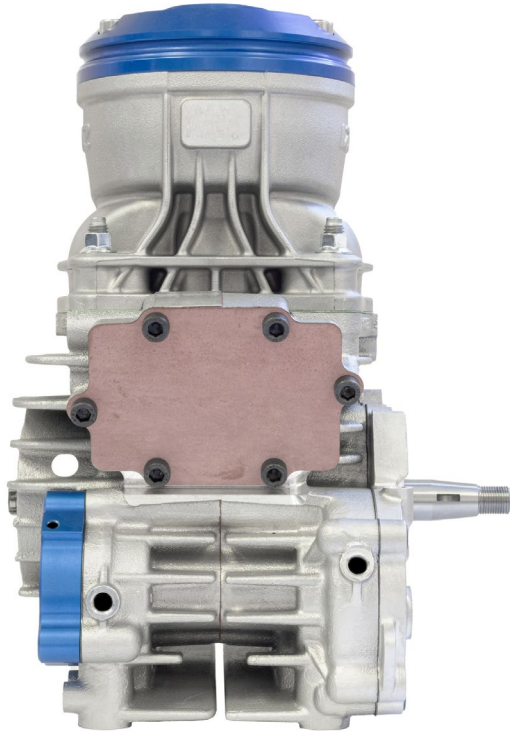

Photo du moteur complet de l'arriere /  
Photo of the complete engine rear side



Photo du moteur complet vu du haut /  
Photo of the complete engine seen from above



Photo du moteur complet vu du dessous /  
Photo of the complete engine seen from below

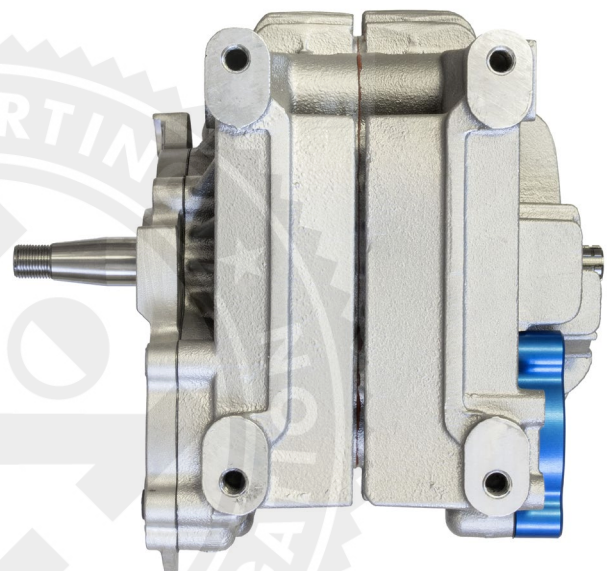



F

**Marquage des pièces principales / Main parts marking**

Pour chaque pièce, photo d'ensemble avec le marquage et photo avec zoom sur le marquage /  
For each part, overall photo with marking and zoomed photo of marking

1. Fonderies des carters droit et gauche
2. Fonderie de cylindre
3. Culasse
4. Chemise en fonte
5. Demi-vilebrequins
6. Bielle
7. Piston
8. Arbre d'équilibrage
9. Engrenages
10. Couvercle d'engrenages

1. Castings of LH & RH crankcases
2. Casting of cylinder
3. Cylinder head
4. Cast iron liner
5. Half-crankshafts
6. Conrod
7. Piston
8. Balance shaft
9. Gears
10. Gears cover

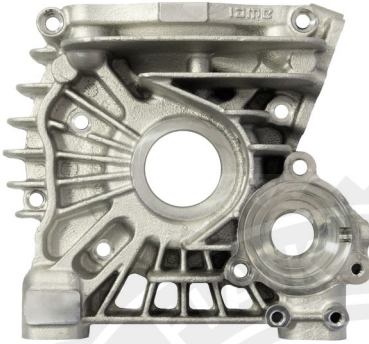
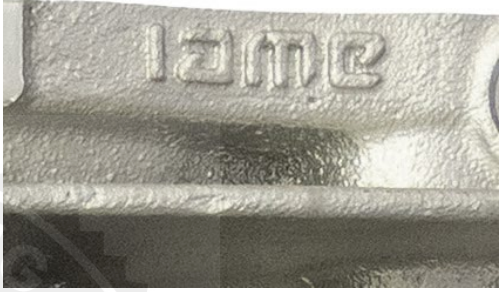
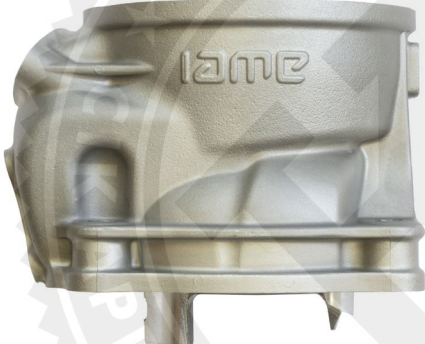
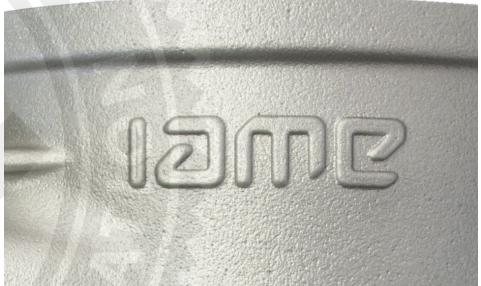
| Pièces N° /<br>Parts no. | Photo d'ensemble / Overall picture  | Zoom  |
|--------------------------|---|---|
| 1                        |   |   |
| 1                        |  |   |
| 2                        |  |  |

|   |   |   |
|---|---|---|
| 3 |    |    |
| 4 |    |    |
| 5 |   |   |
| 6 |  |  |
| 7 |  |   |

|           |  |  |
|-----------|--|--|
| <p>8</p>  |   |   |
| <p>9</p>  |   |   |
| <p>10</p> |  |  |

